

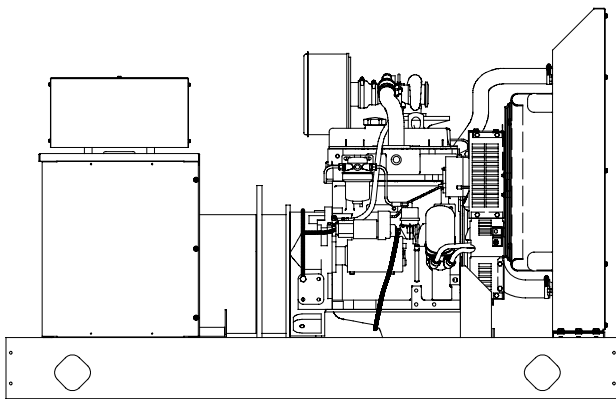

## Ratings Range

		60 Hz	50 Hz
Standby:	kW	25-27	18-21
	kVA	25-34	20-26
Prime:	kW	22-24	17-19
	kVA	23-30	18-24



## Standard Features

- Kohler Co. provides one-source responsibility for the generating system and accessories.
- The generator set and its components are prototype-tested, factory-built, and production-tested.
- The 60 Hz generator set offers a UL 2200 listing.
- The generator set accepts rated load in one step.
- The 60 Hz generator set meets NFPA 110, Level 1, when equipped with the necessary accessories and installed per NFPA standards.
- The generator set complies with ISO 8528-5, Class G2, requirements for transient performance in all generator set configurations. Select the Decision-Maker™ 550 controller for improved voltage regulation and ISO 8528-5, Class G3, compliance.
- A one-year limited warranty covers all systems and components. Two-, five-, and ten-year extended warranties are also available.
- Alternator features:
  - The unique Fast-Response™ II excitation system delivers excellent voltage response and short circuit capability using a permanent magnet (PM)-excited alternator.
  - The brushless, rotating-field alternator has broadrange reconnectability.
- Other features:
  - Controllers are available for all applications. See controller features inside.
  - The low coolant level shutdown prevents overheating (standard on radiator models only).
  - Integral vibration isolation eliminates the need for under-unit vibration spring isolators.

## Generator Set Ratings

Alternator	Voltage	Ph	Hz	130°C Rise Standby Rating		105°C Rise Prime Rating	
				kW/kVA	Amps	kW/kVA	Amps
4P4	120/208	3	60	26/33	90	24/30	83
	127/220	3	60	26/33	85	22/28	72
	120/240	3	60	26/33	78	24/30	72
	120/240	1	60	25/25	104	23/23	96
	139/240	3	60	25/31	75	22/28	66
	220/380	3	60	27/34	51	24/30	46
	240/416	3	60	26/33	45	24/30	42
	277/480	3	60	25/31	38	22/28	33
	347/600	3	60	25/31	30	22/28	26
	110/190	3	50	21/26	79	19/24	73
	115/200	3	50	20/25	72	17/21	61
	120/208	3	50	18/23	64	17/21	58
	110/220	3	50	20/25	66	18/23	60
	110/220	1	50	20/20	91	18/18	82
	220/380	3	50	21/26	40	19/24	36
	230/400	3	50	20/25	36	17/21	30
240/416	3	50	18/23	32	17/21	29	

**RATINGS:** All three-phase units are rated at 0.8 power factor. All single-phase units are rated at 1.0 power factor. *Standby Ratings:* Standby ratings apply to installations served by a reliable utility source. The standby rating is applicable to varying loads for the duration of a power outage. There is no overload capability for this rating. Ratings are in accordance with ISO-3046/1, BS 5514, AS 2789, and DIN 6271. *Prime Power Ratings:* Prime power ratings apply to installations where utility power is unavailable or unreliable. At varying load, the number of generator set operating hours is unlimited. A 10% overload capacity is available for one hour in twelve. Ratings are in accordance with ISO-8528/1, overload power in accordance with ISO-3046/1, BS 5514, AS 2789, and DIN 6271. For limited running time and base load ratings, consult the factory. Obtain the technical information bulletin (TIB-101) on ratings guidelines for the complete ratings definitions. The generator set manufacturer reserves the right to change the design or specifications without notice and without any obligation or liability whatsoever. **GENERAL GUIDELINES FOR DERATION:** *Altitude:* Derate 0.5% per 100 m (328 ft.) elevation above 2500 m (8200 ft.). *Temperature:* Derate 1.0% per 10°C (18°F) temperature above 40°C (104°F).

# Alternator Specifications

Specifications	Alternator
Manufacturer	Kohler
Type	4-Pole, Rotating-Field
Exciter type	Brushless, Permanent-Magnet
Leads: quantity, type	12, Reconnectable
Voltage regulator	Solid State, Volts/Hz
Insulation:	NEMA MG1
Material	Class H
Temperature rise	130°C, Standby
Bearing: quantity, type	1, Sealed
Coupling	Flexible Disc
Amortisseur windings	Full
Voltage regulation, no-load to full-load	
Permanent magnet (PM) alternator	±2% Average
550 controller (with 0.5% drift due to temperature variation)	3-Phase Sensing, ±0.25%
One-step load acceptance	100% of Rating
Unbalanced load capability	100% of Rated Standby Current
Peak motor starting kVA:	(35% dip for voltages below)
480 V, 380 V 4P4 (12 lead)	121 (60 Hz), 88 (50 Hz)

- NEMA MG1, IEEE, and ANSI standards compliance for temperature rise and motor starting.
- Sustained short-circuit current of up to 300% of the rated current for up to 10 seconds.
- Sustained short-circuit current enabling downstream circuit breakers to trip without collapsing the alternator field.
- Self-ventilated and drip-proof construction.
- Vacuum-impregnated windings with fungus-resistant epoxy varnish for dependability and long life.
- Superior voltage waveform from a two-thirds pitch stator and skewed rotor.
- Fast-Response™ II brushless alternator with brushless exciter for excellent load response.

## Application Data

### Engine

Engine Specifications	60 Hz	50 Hz
Manufacturer	John Deere	
Engine model	3029TF150	3029TF120
Engine type	4-Cycle, Turbocharged	
Cylinder arrangement	3 Inline	
Displacement, L (cu. in.)	2.9 (177)	
Bore and stroke, mm (in.)	106 x 110 (4.17 x 4.33)	
Compression ratio	17.2:1	
Piston speed, m/min. (ft./min.)	396 (1299)	330 (1083)
Main bearings: quantity, type	4, Replaceable Insert	
Rated rpm	1800	1500
Max. power at rated rpm, kWm (BHP)	48 (64)	42 (56)
Cylinder head material	Cast Iron	
Crankshaft material	Forged Steel	
Valve material:		
Intake	Chromium-Silicon Steel	
Exhaust	Stainless Steel	
Governor: type, make/model	Mechanical, Stanadyne/DB2	
Frequency regulation, no-load to full-load	3-5%	
Frequency regulation, steady state	±0.33% (mech. governor) ±0.25% (elect. isoch. gov.)	
Frequency	Fixed	
Air cleaner type, all models	Dry	

### Exhaust

Exhaust System	60 Hz	50 Hz
Exhaust manifold type	Dry	
Exhaust flow at rated kW, m³/min. (cfm)	6.9 (243)	5.2 (184)
Exhaust temperature at rated kW, dry exhaust, °C (°F)	423 (793)	437 (819)
Maximum allowable back pressure, kPa (in. Hg)	7.5 (2.2)	
Exhaust outlet size at engine hookup, mm (in.)	63.5 (2.5)	

### Engine Electrical

Engine Electrical System	60 Hz	50 Hz
Battery charging alternator:	12 Volt	
Ground (negative/positive)	Negative	
Volts (DC)	12	
Ampere rating	55	
Starter motor rated voltage (DC)	12	
Battery, recommended cold cranking amps (CCA):		
Quantity, CCA rating	One, 640	
Battery voltage (DC)	12	

### Fuel

Fuel System	60 Hz	50 Hz
Fuel supply line, min. ID, mm (in.)	11.0 (0.44)	
Fuel return line, min. ID, mm (in.)	6.0 (0.25)	
Max. lift, fuel pump: type, m (ft.)	Engine-Driven, 1.8 (6.0)	
Max. fuel flow, Lph (gph)	112 (29.6)	108 (28.6)
Fuel prime pump	Manual	
Fuel filter		
Secondary	8 Microns @ 98% Efficiency	
Water Separator	Yes	
Recommended fuel	#2 Diesel	

### Lubrication

Lubricating System	60 Hz	50 Hz
Type	Full Pressure	
Oil pan capacity, L (qt.)	7.6 (8.0)	
Oil pan capacity with filter, L (qt.)	8.5 (9.0)	
Oil filter: quantity, type	1, Cartridge	
Oil cooler	Water-Cooled	

# Application Data

## Cooling

Radiator System	60 Hz	50 Hz
Ambient temperature, °C (°F)	50 (122)	
Engine jacket water capacity, L (gal.)	5.7 (1.5)	
Radiator system capacity, including engine, L (gal.)	13.6 (4.6)	
Engine jacket water flow, Lpm (gpm)	110 (29)	91 (24)
Heat rejected to cooling water at rated kW, dry exhaust, kW (Btu/min.)	18.3 (1040)	14.1 (800)
Water pump type	Centrifugal	
Fan diameter, including blades, mm (in.)	483 (19)	
Fan, kWm (HP)	2.1 (2.8)	1.5 (2.0)
Max. restriction of cooling air, intake and discharge side of radiator, kPa (in. H <sub>2</sub> O)	0.125 (0.5)	

Remote Radiator System†	60 Hz	50 Hz
Exhaust manifold type	Dry	
Connection sizes:		
Water inlet, ID hose, mm (in.)	48 (1.88)	
Water outlet, ID hose, mm (in.)	38 (1.50)	
Static head allowable above engine, kPa (ft. H <sub>2</sub> O)	63 (21)	

† Contact your local distributor for cooling system options and specifications based on your specific application.

## Operation Requirements

Air Requirements	60 Hz	50 Hz
Radiator-cooled cooling air, m <sup>3</sup> /min. (scfm)‡	91 (3200)	76 (2700)
Cooling air required for generator set when equipped with city water cooling or remote radiator, based on 14°C (25°F) rise and ambient temp. of 29°C (85°F), m <sup>3</sup> /min. (cfm)	43 (1500)	37 (1300)
Combustion air, m <sup>3</sup> /min. (cfm)	3.3 (117)	2.4 (85)
Heat rejected to ambient air:		
Engine, kW (Btu/min.)	7.0 (400)	5.7 (325)
Alternator, kW (Btu/min.)	4.6 (260)	4.3 (245)

‡ Air density = 1.20 kg/m<sup>3</sup> (0.075 lbm/ft<sup>3</sup>)

Fuel Consumption	60 Hz	50 Hz
<b>Diesel, Lph (gph) at % load</b>	<b>Standby Rating</b>	
100%	8.6 (2.3)	7.0 (1.8)
75%	6.7 (1.8)	5.6 (1.5)
50%	4.9 (1.3)	4.2 (1.1)
25%	3.1 (0.8)	2.5 (0.7)
<b>Diesel, Lph (gph) at % load</b>	<b>Prime Rating</b>	
100%	7.6 (2.0)	6.5 (1.7)
75%	5.9 (1.6)	5.1 (1.3)
50%	4.4 (1.2)	3.8 (1.0)
25%	3.5 (0.9)	2.6 (0.7)

# Controllers

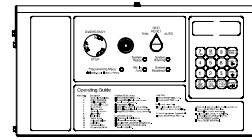

### Decision-Maker™ 550 Controller

Audiovisual annunciation with NFPA 110 Level 1 capability. Programmable microprocessor logic and digital display features. Alternator safeguard circuit protection. 12- or 24-volt engine electrical system capability. Remote start, remote annunciation, and remote communication options. Refer to G6-46 for additional controller features and accessories.

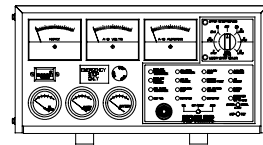

### Decision-Maker™ 3+, 16-Light Controller

Audiovisual annunciation with NFPA 110 Level 1 capability. Microprocessor logic, AC meters, and engine gauge features. 12- or 24-volt engine electrical system capability. Remote start, prime power, and remote annunciation options. Refer to G6-30 for additional controller features and accessories.

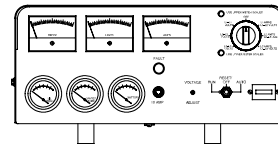

### Decision-Maker™ 1 Controller

Single-light annunciation and basic controls with NFPA capability. Relay logic, AC meters, and engine gauge features. 12-volt engine electrical system capability only. Remote or automatic start options. Refer to G6-29 for additional controller features and accessories. **Note:** Not available with 600-volt alternator.

## Additional Standard Features

- Alternator Protection (standard with 550 controller)
- Battery Rack and Cables
- Integral Vibration Isolation
- Oil Drain Extension
- Operation and Installation Literature

## Available Accessories

### Enclosed Unit

- Sound Enclosure (with enclosed critical silencer)
- Weather Enclosure (with enclosed critical silencer)
- Weather Housing (with roof-mounted critical silencer)

### Open Unit

- Exhaust Silencer, Critical (kit: PA-352663)
- Exhaust Silencer, Hospital (kit: GM32386-KP1)
- Flexible Exhaust Connector, Stainless Steel

### Cooling System

- Block Heater  
(recommended for ambient temperatures below 0°C [32°F])
- Radiator Duct Flange
- Remote Radiator Cooling

### Fuel System

- Auxiliary Fuel Pump
- Flexible Fuel Lines
- Fuel Pressure Gauge
- Subbase Fuel Tanks
- Subbase Fuel Tank with Day Tank

### Electrical System

- Battery
- Battery Charger, Equalize/Float Type
- Battery Heater

### Engine and Alternator

- Air Cleaner, Heavy Duty
- Air Cleaner Restriction Indicator
- Alternator Strip Heater
- Bus Bar Kits
- Closed Crankcase Vent
- CSA Certification
- Current Transformer Kit
- Electronic Isochronous Governor ( $\pm 0.25\%$  freq. reg. steady state)
- Line Circuit Breaker (NEMA type 1 enclosure)
- Line Circuit Breaker with Shunt Trip (NEMA type 1 enclosure)
- Rated Power Factor Testing
- Rodent Guards
- Safeguard Breaker (not available with 550 controller)
- Skid End Caps

### Paralleling System

- Reactive Droop Compensator
- Voltage Adjust Control
- Voltage Regulator Relocation Kit

### Maintenance

- General Maintenance Literature Kit
- Maintenance Kit (includes standard air, oil, and fuel filters)
- NFPA 110 Literature
- Overhaul Literature Kit
- Production Literature Kit

### Controller (550 and 16-Light Controllers)

- Common Failure Relay Kit
- Communication Products and PC Software (550 controller only)
- Customer Connection Kit
- Dry Contact Kit (isolated alarm)
- Engine Prealarm Sender Kit
- Prime Power Switch (550 controller only)
- Remote Annunciator Panel
- Remote Audiovisual Alarm Panel
- Remote Emergency Stop Kit
- Remote Mounting Cable
- Run Relay Kit

### Miscellaneous Accessories

- \_\_\_\_\_
- \_\_\_\_\_
- \_\_\_\_\_
- \_\_\_\_\_

## Dimensions and Weights

Overall Size, L x W x H, mm (in.):

Wide Skid: 2000 x 1040 x 1274 (78.74 x 40.94 x 50.15)

Narrow Skid: 2000 x 864 x 1274 (78.74 x 34.02 x 50.15)

Weight (radiator model), wet, kg (lb.): 685 (1510)

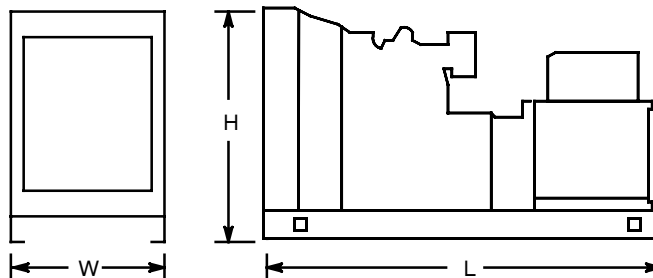

NOTE: This drawing is provided for reference only and should not be used for planning installation. Contact your local distributor for more detailed information.

## DISTRIBUTED BY: