

REV	DATE	REVISION	BY
B	10-7-04	(B,C-4) "N" LEAD MOVED FROM GROUND LUG TO GROUND BUS BAR; "CC" LEAD RELOCATED ON GROUND BUS BAR [73528]	DFS
C	10-28-04	(A-1,-2) GENERIC TITLE BLOCK ADDED [73512]	DFS
D	4-1-05	(B-7-8) P2 PIN 1 & 6 DESIGNATORS ADDED; "COMMON FAILURE" TERMINAL FUNCTION MOVED FROM PINS 1 & 2 TO PINS 5 & 6; "LOAD CONTROL" TERMINAL FUNCTION MOVED FROM PINS 5 & 6 TO PINS 1 & 2; TERMINAL DESCRIPTIONS REVISED [74777]	DFS

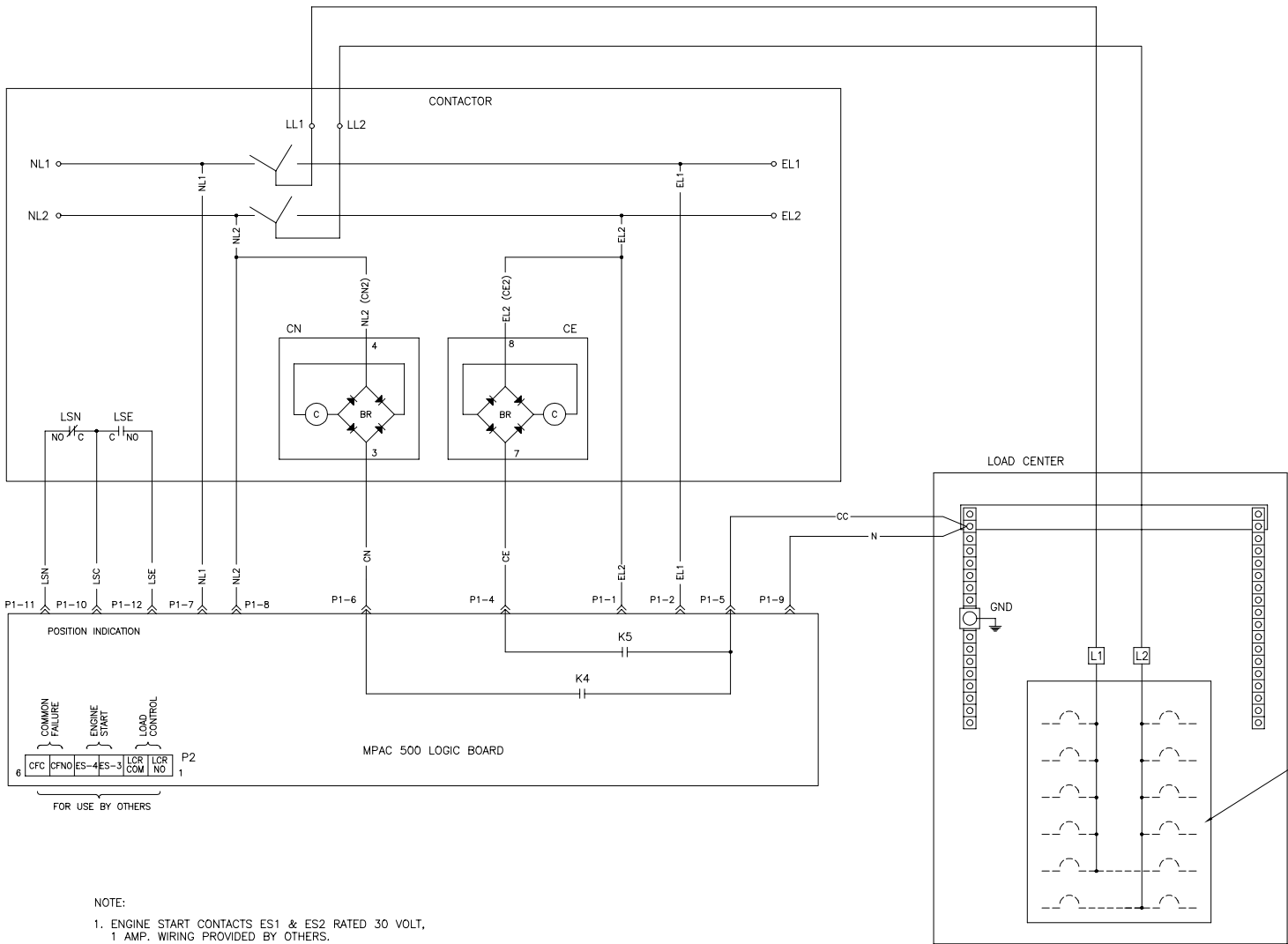

LEGEND

- BR BRIDGE RECTIFIER
- C COIL
- CE TRANSFER COIL (EMERGENCY TRANSFER)
- CN TRANSFER COIL (NORMAL TRANSFER)
- K4 NORMAL RELAY CONTACTS
- K5 EMERGENCY RELAY CONTACTS
- LSE LIMITS SWITCH EMERGENCY CONTACTS
- LSN LIMIT SWITCH NORMAL CONTACTS
- P1 CONNECTOR

- NOTE:
- ENGINE START CONTACTS ES1 & ES2 RATED 30 VOLT, 1 AMP. WIRING PROVIDED BY OTHERS.
 - CONTACTOR SHOWN IN NORMAL WITH NO POWER APPLIED.
 - FOR WIRING DIAGRAM SEE GM37650

CIRCUIT BREAKER AREA (BREAKERS SUPPLIED BY OTHERS)

UNLESS OTHERWISE SPECIFIED - 1. TERMINALS SHALL BE WIRE JONES 2010 SIZE 1/2" JAN 2, 2000 DIMENSIONS FROM A, B AND C - 7" MAX. FRACTURES 1/16"		KOHLER CO. POWER SYSTEMS, KOHLER, WI 53044 U.S.A. THIS DRAWING IS SPONSORED AND CONTROLLED BY KOHLER CO. PROPERTY AND MUST NOT BE USED EXCEPT IN CONNECTION WITH KOHLER CO. WORK. ALL RIGHTS OF DESIGN OR INVENTION ARE RESERVED.	
DIAGRAM, SCHEMATIC		SHEET 1-1	
APPROVALS DESIGNED: DFS DRAWN: JS APPROVED: JS	DATE 7-14-04 7-15-04 7-15-04	SCALE: // / DRAWING NO.: GM37649.DWG REV. NO.: GM37649	SHEET: 1-1

MPAC 500
100-200A W/LOAD CENTER